

EFFECT OF ANNEALING ON STRUCTURES AND EFFECTIVE THERMAL CONDUCTIVITY OF $\text{Se}_{90}\text{In}_{10}$ CHALCOGENIDE GLASS

Abhay Kumar Singh^a, Kedar Singh^a, N.S.Saxena^b

^a*Department of Physics, Faculty of Science, Banaras Hindu University, Varanasi-221005, India*

^b*Semiconductor and Polymer Science Laboratory, 5-6 Vigyan Bhawan, Department of Physics, University of Rajasthan, Jaipur 302004, India*

The annealing phenomena have been observed on the pellets of $\text{Se}_{90}\text{In}_{10}$ chalcogenide glass by annealing at 50 °C and 100 °C for 2h. The structure and effective thermal conductivity of as prepared and annealed samples of $\text{Se}_{90}\text{In}_{10}$ chalcogenide have been investigated by XRD and transient plane source (TPS) method, respectively. A considerable change has been found in both structures and effective thermal conductivity for annealing at 50 °C (2h). However, by annealing at 100 °C for 2h the glassy $\text{Se}_{90}\text{In}_{10}$ transforms into crystalline $\text{Se}_{90}\text{In}_{10}$ and its effective thermal conductivity drastically decreases. Therefore, the change of the structure and of the effective thermal conductivity of $\text{Se}_{90}\text{In}_{10}$ chalcogenide glassy material evidence specific structural relaxation phenomena.

(Received September 1, 2008; accepted September 14, 2008)

Keywords: Annealing phenomena, Phase transformation, Effective thermal conductivity, Chalcogenide glass.

1. Introduction

In recent years, much attention has been paid to the III-VIth group chalcogenide materials, mainly due to their wide range of applicability as solid state devices in scientific and technological fields. The phase transformation of chalcogenide glasses has played an important role in their applicability [1-5]. The phase transformations are encountered in many processes and are of great practical importance. Therefore, they are intensively studied. Since thermo-analytical techniques are simple and informative, they intensively being employed to investigate their structural relaxation in annealing conditions [6]. The structural relaxation is the kinetically independent rearrangements of the temperature dependent structures of a liquid and is accompanied by changes in the macroscopic properties. The structural changes occur in glassy $\text{Se}_{90}\text{In}_{10}$ chalcogenide material because disorder and defects arise during heat treatment.

Amorphous selenium holds an important role among the chalcogenide glasses and is widely used as amorphous semiconductor [7]. However, selenium based binary chalcogenide glasses are found to be more useful in practical applications than pure selenium. From the technological point of view these glasses should be thermally stable with time and temperature during use [8]. In present study, we report the effect of annealing temperatures on structure and thermal conductivity of $\text{Se}_{90}\text{In}_{10}$ chalcogenide glass. The $\text{Se}_{90}\text{In}_{10}$ chalcogenide glass was annealed at 50°C and 100°C temperatures for 2h. The structure of as prepared and annealed samples have been investigated by using XRD, and the effective thermal conductivity of the $\text{Se}_{90}\text{In}_{10}$ chalcogenide glass has been measured by transient plane source (TPS) techniques.

2. Material preparation and experimental techniques

High purity (99.999%) Selenium and Indium in the appropriate atomic percentage were weighed and then sealed into quartz ampoule (length 7 cm and internal diameter 8 mm) in a vacuum of 10^{-5} to 10^{-6} Torr. The sealed ampoule was heated in an electric furnace up to 925 K (± 5 K) and kept around that temperature for 8-9 h. During heating period, the ampoule was continuously rocked after every 2 h to ensure the homogeneity of the sample. The molten sample was rapidly quenched in ice cooled water. The prepared material was processed into the form of pellets (thickness 2 mm and diameter 12 mm) at a load of 5 tons. The prepared pellets of $\text{Se}_{90}\text{In}_{10}$ chalcogenide glass was annealed at 50 $^{\circ}\text{C}$ and 100 $^{\circ}\text{C}$ for 2h. The structure of as prepared and annealed samples were investigated by X' Pert Pro X-ray diffractometer with Cu K_{α} radiation (1.54 \AA) and the effective thermal conductivity of the $\text{Se}_{90}\text{In}_{10}$ chalcogenide glass was measured by transient plane source (TPS) technique.

The TPS sensor shown in Fig. 1 is sandwiched between the two pellets of sample material in the sample holder shown in Fig. 2. Schematic diagram of electrical circuit used for measurement of effective thermal conductivity is shown in Fig.3. Several runs of the experiment are performed and recorded at room temperature to ensure the reproducibility of these results. Also, to attain thermal equilibrium, the samples were maintained at a room temperature for at least 2 h before the experimental data were recorded. The change in the voltage was recorded with a digital voltmeter, which was online to the personal computer. The power output to the sample was adjusted according to the nature of the sample material, in most of cases range is 6×10^{-6} to 16×10^{-6} W/m^2 .

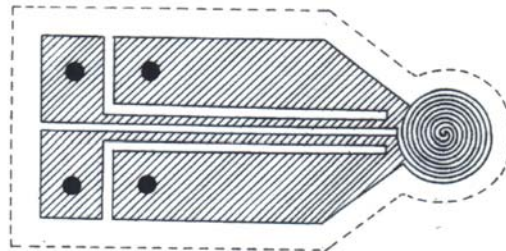

Fig. 1. Schematic diagram of TPS sensor.

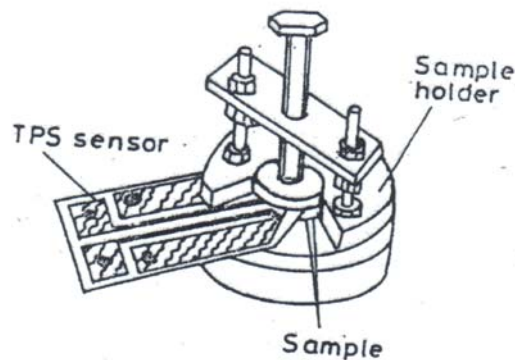

Fig. 2. Sample holder diagram with TPS sensor

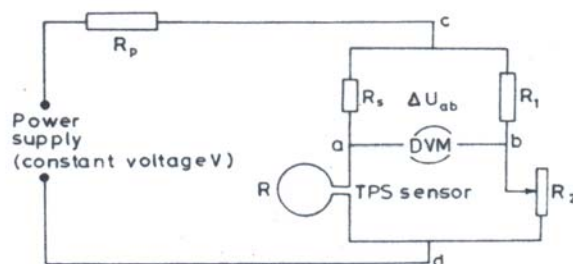

Fig. 3. Schematic diagram of the electrical circuit used for measurement of effective thermal conductivity.

The TPS element is made of a $10\ \mu\text{m}$ thick nickel foil (having a resistance of about $3.26\ \Omega$ and TCR around $4.6 \times 10^{-3}\ \text{K}^{-1}$) with an insulating layer made of $50\ \mu\text{m}$ thick Kapton, on each side of the metal pattern. Evaluation of these measurements was performed in a way that was outlined by Gustafsson [9]. In experiments with insulating layers of such thickness, it is necessary to ignore the voltage recorded during the first few seconds because of the influence of the insulating layers. However, owing to the size of the heated area of the TPS element, the characteristic time of the experiment is so long that it is possible to ignore a few second of recorded potential difference values and still obtain very good result.

An important aspect of the design of any TPS element is that the pattern should be such that as large a part of the “hot” area as possible should be covered by the electrically conducting pattern, as long as there is insulation between the different parts of the pattern. This is particularly important, when insulating layers are covering the conduction pattern and the surface(s) of the sample. It should be noted that the temperature difference across the insulating layer can after a short initial transient, be considered constant.

3. Results and discussion

XRD patterns of $\text{Se}_{90}\text{In}_{10}$ as prepared, annealed at 50°C and 100°C for 2h are shown in Fig.4 (a, b, c). It is observed From Fig. 4(a) the absence of crystalline peaks in XRD pattern of as prepared $\text{Se}_{90}\text{In}_{10}$ chalcogenide glass. Therefore, as prepared $\text{Se}_{90}\text{In}_{10}$ sample is a glassy alloy. The XRD pattern at 50°C annealed $\text{Se}_{90}\text{In}_{10}$ chalcogenide has also exhibits amorphous glassy state with a small hump 20-30 of 2θ values, as shown in Fig. 4(b). The presence of small hump in XRD pattern has been indicating that the $\text{Se}_{90}\text{In}_{10}$ glassy system gone under structural relaxation and phase transformation within glassy region at 50° annealed for 2h. However, XRD pattern of as prepared $\text{Se}_{90}\text{In}_{10}$ chalcogenide glassy alloy is not showing such type of hump. Further, XRD pattern of $\text{Se}_{90}\text{In}_{10}$ chalcogenide glassy alloy annealed at 100°C for 2h exhibits a complete phase transformation from glassy state to crystalline state. This is confirmed by the presence of two crystalline peaks in XRD pattern. These two crystalline peaks are identified as SeIn and In_2Se_3 compounds, as shown in Fig.4 (c). Therefore, the $\text{Se}_{90}\text{In}_{10}$ chalcogenide glass at 50°C annealed for 2h may have some physical and scientific significance, due to presence of small hump within glassy region.

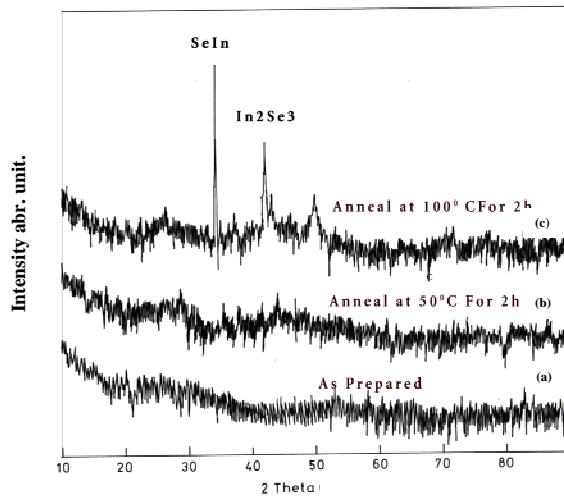

Fig.4. XRD patterns of $\text{Se}_{90}\text{In}_{10}$ chalcogenide glass (a) as prepared, (b) annealed at 50°C and (c) annealed at 100°C for 2h.

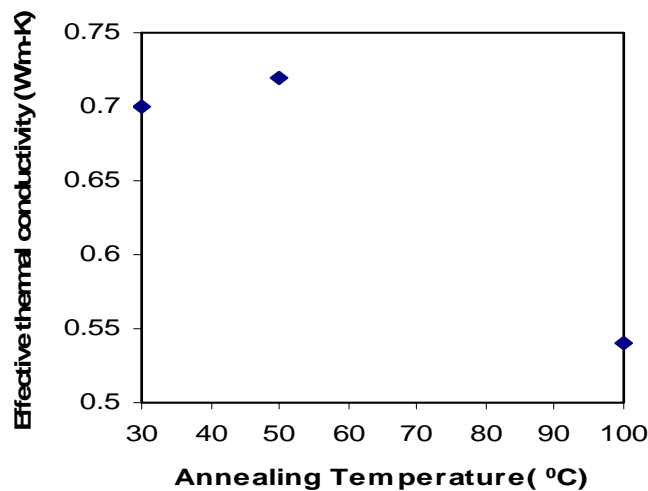

Fig.5. Variation of effective thermal conductivity with annealing temperatures of $\text{Se}_{90}\text{In}_{10}$ chalcogenide glass.

The variation of effective thermal conductivity with annealing temperatures of $\text{Se}_{90}\text{In}_{10}$ chalcogenide glass is shown in Fig. 5. It is observed from Fig.5, that the effective thermal conductivity is maximum for 50°C annealed sample, the annealing temperature which lies at vicinity of glass transition temperature. It is well known for chalcogenide glasses more structural relaxation has occurred at the vicinity of glass transition temperature. Therefore, the value of effective thermal conductivity is maximum at 50°C annealed sample, due structural relaxation of $\text{Se}_{90}\text{In}_{10}$ chalcogenide glass. On other hand XRD pattern is showing a hump at same (50°C) annealing temperature, which supports to structural relaxation phenomena of $\text{Se}_{90}\text{In}_{10}$ chalcogenide glass.

Structural relaxation phenomena of $\text{Se}_{90}\text{In}_{10}$ glassy system could be explained as; the generally accepted structural model of amorphous Se includes [10] two molecular species, meandering chain, which contain helical chains of trigonal Se and Se_8 rings molecules of

monoclinic Se. The heavily crosslink heteropolar bonds accepted to occur in structure of $\text{Se}_{90}\text{In}_{10}$ chalcogenide glassy alloy with bond energy (54.0 Kcal/mole) [11]. It is reported [12] that, in crosslinking of glasses bonds interchange to be occur, the interchange bonds must break them and reform after the structure has been relaxed.

In the vicinity of glass transition temperature, the unsaturated covalent van-der-Waals like bonds are broken in highest percent and chains straighten out more and more, while the cross linking density of material becomes minimum. Therefore, phonon mean free path becomes maximum. It could be the reason of existence of maximum effective thermal conductivity of $\text{Se}_{90}\text{In}_{10}$ chalcogenide glass at 50°C annealed for 2h. However, the effective thermal conductivity is decreased as annealed temperature (100°C) increases. The decrease in effective thermal conductivity at 100°C annealed temperature is due to the transition from glassy state to crystalline state. The chains break into small chain segments and undergo intensive thermal motion, due to breaking of strong covalent bonds of Se-In chalcogenide glassy alloy. Therefore, the thermally relaxed structure of $\text{Se}_{90}\text{In}_{10}$ glassy alloy leads to the transformation into crystalline $\text{Se}_{90}\text{In}_{10}$ chalcogenide alloy. Moreover, the complete phase transformation of 100°C annealed $\text{Se}_{90}\text{In}_{10}$ glass has been also verified by XRD pattern as shown in Fig.4(c).

5. Conclusion

It is concluded from the above studies that, the structures and effective thermal conductivity of $\text{Se}_{90}\text{In}_{10}$ chalcogenide glass change with annealing temperatures due to structural relaxation and phase transformation. The $\text{Se}_{90}\text{In}_{10}$ chalcogenide glass at 50°C annealed for 2h is more thermally stable than other annealed samples.

Acknowledgement

We are thankful to Council of Scientific and Industrial Research (CSIR), New Delhi (India) for providing financial support to research work (CSIR Project. No.03(1063)/06/EMR-II). We are also thankful to Prof. O.N. Srivastava which helped in various ways during this work.

References

- [1] A. Keneman, Appl. Phys. Lett. **19**, 205 (1971).
- [2] J.S. Berkes, S.W. Lng, W.J. Hillegas, J. Appl. Phys. **42**, 5908 (1971).
- [3] A.V. Koloboy (Ed), Photo-induced Metastability in amorphous semiconductors, Wiley-VCH, Weinheim, 2003.
- [4] V. Lyubin, M. Klebanov, A. Mitkova, T. Petkova, J. Non-Cryst. Solids **739**, 227 (1998).
- [5] V. Lyubin, M. Klebanov, A. Felgel, B. Sfez, Thin Solid Films **183**, 459 (2004).
- [6] M.M.A. Imran, D. Bhandari, N.S. Saxena, J. Materials Science Letters **19**, 1607 (2000).
- [7] A. Reznik, B.J. M.Lui, V. Lyubin, M. Kelbanov, Y. Ohkawa, T. Matsubara, K. Miyakawa, M. Kubota, K. Tanioka, T.Kawai, J.A. rowlands, J. Non-Cryst.Solids **352** 1595 (2006).
- [8] A.B. Abd El-Moiz, N.Afify, Nafiz, Physica B **182**, 33 (1992).
- [9] S.E. Gustafsson, Rev. Sci. Instrum **62**, 797 (1991).
- [10] G. Lucovsky, J.Non-Cryst.Solids **97/98**, 3950 (1987).
- [11] M.M.A. Imran, N.S. Saxena, D. Bhandari, M. Husain, phys. stat. sol (a) **181**, 357 (2000).
- [12] A.N. Sreeram, D.R. Swiler, A.K. Varshneya, J. Non-Cryst. Solids **127**, 287 (1991).